



The mini power plant of the future 3

Weiss puts DTU research to use 6

From waste water sludge to green oil 9

Re-establishing the biogas process 10

Biogas experiments on a large scale 12

Courses for project applicants 14

Completed projects 15

Biodiesel protects our health but strains the environment 16

Biomasses are directly converted into electricity in a fuel cell

Large, complex plants that produce gas or liquid fuels based on biomasses might only be a passing phenomenon. It is already possible to convert biomasses directly into electricity in a fuel cell, and if we succeed in making this technology commercially accessible, biomasses and waste will turn into an extremely valuable source of energy.

By Torben Skøtt

It sounds too good to be true. Add a dash of waste water sludge or some other type of biomass to a fuel cell and the cell will start producing electricity. So far, we have not been able to generate vast amounts of energy in this way; however, the fact that it is possible bears witness to a concept with a probable potential of checkmating many other bioenergy technologies.

Worldwide, only four research teams are currently working with fuel cells for biomasses. One of them is based at the DTU-RISØ and the others in the USA, Belgium and The Netherlands.

Project researcher Anders Thygesen and senior researcher Anne Belinda Thomsen from RISØ, as well as Post Doc Booki Min and Professor Irini Angelidaki from the Danish University of Technology (DTU), are working on this new technology. In recent years, they have, amongst other things, been able to build a series of small, microbial fuel cells now used in various experiments. So far, an electrical voltage difference between the fuel cells electrodes of 0.6 volt has been obtained and future experiments will be carried out with a view to maximise voltage and make it last as long as possible.

0.6 volt seems like a very small amount, however, it is not far from the voltage of around 1 volt rendered by a normal fuel cell. In order to reach a usable voltage level, several fuel cells will have to be connected in a series in order to



Researchers now want to utilise residual products from ethanol production to generate electricity within a fuel cell. This picture is from the IBUS plant close to Skærbæk, where the ethanol production is based on straw.

This is how the fuel cell works

The principle behind a fuel cell is basically to kick-start the transport of electrons between two electrodes. In a traditional fuel cell, this is done by providing one of the electrodes with oxygen and the other with hydrogen, as an example. Each hydrogen atom splits into a proton and an electron, and they each choose their route within the circuit. Whereas the proton will pick the fastest route through the membrane, the electron is unable to do that, and this is how an electrical voltage difference occurs between the two electrodes. In a microbial fuel cell, the proton and electron split takes place by means of microorganisms.

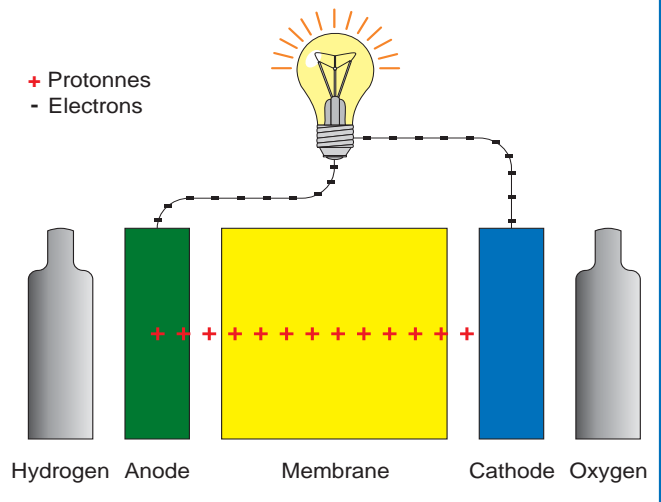

achieve a normal plug voltage level of 220 volt.

Microorganisms

In many ways, a microbial fuel cell resembles a normal fuel cell, but instead of adding fuel in the form of hydrogen, we use waste water sludge or some other type of biomass. Waste water sludge nutrients can be disintegrated by means of microorganisms, whereby hydrogen ions and free electrons are generated. In turn, these create electrical power between the two cell electrodes.

At RISØ, waste water sludge has been the main raw material source but also experiments using residual products from the production of ethanol based on straw have been carried out. Amongst other things, this would be hemicelluloses and ethanoic acid, which require a large amount of energy to be converted into ethanol.

– The current results are promising and it seems that those materials, which are less appropriate for ethanol production, will be more useful in a fuel cell, Anders Thygesen explains. He does not

hesitate in calling the microbial fuel cell a brilliant invention; however, he is also fully aware that a commercial break-through might take a while.

– It is not an easy task but we believe in the idea and the possibility of solving various problems in collaboration with foreign researchers working on similar projects, says Anders Thygesen.

Challenges

At DTU-RISØ, the research team has been focusing on finding out what type of biological material would be the eas-

iest to convert into electricity; however, the years to come will also see a range of experiments on fuel cell design.

According to Anders Thygesen, internal cell resistance will be one of the research topics; high levels of resistance leads to large energy losses and a lower cell efficiency level.

– We need to minimise the distance between the electrodes and create a surface, which is as large as possible, in order to provide the best possible bacterial growth conditions, Anders Thygesen explains. He is planning on going to the USA at some point in order to take a look at the American researchers' attempts to optimise fuel cell efficiency.

The experiments at DTU-RISØ are financially supported by the Danish Agency for Science and Technology Innovation and have been allotted a total budget of

DKK 4 million. At RISØ, the project is carried out within their Biosystem Department, whereas the Danish University of Technology has allocated the work to their Institute for Environment and Resources. ■

Bioenergy Research (FiB) in Danish and English

A printed version of Bioenergy Research (FiB) is only available in Danish; however, the electronic version exists in Danish as well as English. Visit www.biopress.dk if you would like to subscribe to the magazine or change your current subscription.

BioPress

+45 8617 8507
www.biopress.dk

Fuel cells: An old invention

The fuel cell was already discovered in 1839 but only recently did we realise how brilliant this invention really is.

Fuel cells are no new invention. In 1839, the English physicist Sir William Grove discovered that by splitting water into oxygen and hydrogen, one would be able to make the process move in the opposite direction afterwards. When turning off the power source that had caused the split, the small amounts of oxygen and hydrogen left on the electrodes would generate electrical power.

This was in fact the invention of the fuel cell; however, it was not put to practical use until the 1960s when it was used as a source of electricity and water production in space crafts.

Whereas the 1980s saw a few experiments on fuel cells for cars, research and development of fuel cells did not really take off until the 1990s. Within relatively few years, we managed to reduce the size of fuel cells by factor ten and at the same time, the price was significantly reduced.

Nowadays, most large car factories work with fuel cells and many people are expecting fuel cells to take over a significant part of the electricity production of the future based on a high efficiency level, a minimal pollution level as well as long durability, the latter due to the lack of moveable parts within the cell.

In terms of price, fuel cells are still unable to compete with traditional supply plants, and it will probably be another five to ten years before a commercial break-through is in sight. Within this area, Denmark possesses internationally acknowledged research and development competence within this area, which will play an important role from a business point of view.

TS

The mini power plant of the future



photo: torben skøtt/blopress

Following 15 years of research at the Danish University of Technology, the Stirling engine is now on its way to a commercial break-through. Stirling Danmark, calling their small, effective engines "the mini power plants of the future", now needs to carry out further development and marketing measures with regards to this technology.

By Lars Jagd

A Stirling engine is unique because it is driven by heat from an external source. As opposed to an internal combustion engine, no combustion takes place inside the engine. Therefore, the Stirling engine can be driven by literally any type of fuel. As an example, the Stirling engine may be fitted onto existing or new wood chip boilers in order to produce electricity by means of combustion heat.

In the future, the co-operative society in Hjortshøj by Århus will receive electricity and heating from a recently developed Stirling plant delivered by Stirling Danmark.

At Stirling Danmark we have specialised in production, sales and development of Stirling technology. The company was established based on 15 years of research at the Danish University of Technology, and recent investment by a number of investors, including SEEDCapital, Vækstfonden and EGJ Udvikling, have made it possible for us to introduce our technology at a commercial level.

The technology of Stirling Danmark enjoys a unique position in the market of electricity production based on biomasses within plants with a capacity of up to 500 kW. Currently, no other producers or researchers are able to present a competitive product containing a similar type of technology, and thus Stirling Danmark has a large commercial potential on a global basis.

▶ **The technology**

The engines produced by Stirling Danmark are specifically developed to utilise biological fuel materials in the form of solid biomasses such as wood and straw, liquid bio fuels and biogas.

The engines are constructed according to a modular principle, whereby the basic engines consist of a 1-cylinder/9 kW engine and a 4-cylinder/35kW engine. They may be combined in pairs, allowing for a total of four engine sizes of 9, 18, 35 and 70 kW respectively. Furthermore, it is possible to run several engines parallel to each other, which means that one single plant can reach an installed output of 500 kW or more. In this way, the engines cover a wide range and may be utilised in a variety of configurations, e.g. along with a boiler, a countercurrent gasifier or a pyrolysis unit.

A Stirling CHP plant is a decentralised CHP technology featuring a high level of energy utilisation - even in small plants. The total energy utilisation level is typically around 90% at an electrical efficiency level of up to around 20%.

In Denmark, the generated heat will normally be used as district or process heating; however, the heat may also be connected to an absorption cooling plant or to a desalting plant. In a 3rd world country, where the heat might not be needed as such, the technology could be put to use within the production of electricity and clean drinking water based on rice and salt water.



photo: torben skott/biopress

Gunnar Boye Olesen, from the co-operative society in Hjortshøj, in front of the new Stirling plant that will supply electricity and heating to the low-energy-buildings containing 80 residential units so far. The 4-cylinder Stirling engine, located at the top of the picture, is connected to a wood chip boiler from the machine factory REKA. The co-operative society in Hjortshøj is a co-housing scheme that has been establishing green housing units since 1991. The co-operative society's electric company had the plant put up and received financial support for this project from the Danish Energy Agency.

Potential

The technology possesses an extremely high market potential:

1. This is a unique technology for decentralised CHP production based on CO₂-neutral, locally available fuels.
2. It can be put to use in various ways. Typical clients include CHP plants, industrial companies, farmers, housing associations and owners of public buildings such as sports centres and town halls.
3. The technology is relevant to a variety of geographical markets, including industrialised countries with a preference for green technologies;

developing countries; isolated areas not connected to a transmission network; and disaster zones with fuel supply problems. Within these markets, the Stirling technology may replace diesel generators as the typically used production technology.

In Denmark, some 7,000 buildings have a yearly heating consumption of more than 3,200 GJ. A realistic goal would be to supply around 10% of these buildings with a Stirling plant featuring an electrical effect of a minimum of 35 kW. The complete European market is expected to contain more than 10,000 plants and the global market is obviously many times that size. ▶



Left: 9 kW/1-cylinder Stirling engine from Stirling Danmark.

Right: 35 kW/4-cylinder Stirling engine from Stirling Danmark. Both engines can be combined in pairs in order to obtain an effect of 18 kW and 70 kW respectively.



Gasification or boiler

As the Stirling engine only needs heat to be able to run, it may be combined with a boiler, a gasifier or a pyrolysis reactor.

The simplest solution is to install the engine on top of a standard boiler; however, this solution does not lead to a particularly high efficiency level. By using a boiler specifically designed for this purpose, the efficiency level can be increased significantly. The problem is, however, that such a boiler also increases the price and that the boiler producers take a relatively long time to deliver tailor-made plants.

Stirling Denmark now delivers CHP plants with three different combustion technologies, and such plants are based on Stirling engines. The three technologies are boilers, countercurrent gasifiers and pyrolysis reactors. Whereas the



photo: torben skott/biopress

Test plant in Ansager in the south of Jutland where a countercurrent gasifier generates energy for a Stirling engine. The plant features an electrical efficiency level of 40 kW.

boiler solution is the simplest and the countercurrent gasifier the most efficient solution, the pyrolysis reactor is

the suitable solution for more complex fuel types.

– Pyrolysis gasification allows for around half of the energy to be extracted in the form of charcoal that can either be burned or used for earth improvement purposes. This makes it a slightly special solution but the advantage of it is that basically all types of biomass can be used, including waste, explains Lars Jagd, managing director at Stirling Denmark.

He does not consider it more complicated to convert biomasses to gas instead of heat; however, he does acknowledge that the term “gasifier” has a slightly negative image amongst many people. The managing director points out that the types of gasifier applied by Stirling Denmark are very reliable and, in many ways, feature a simpler design than that of a boiler specifically designed for this purpose. *TS*

According to numbers published by the Danish Energy Agency, 552 grams of CO₂ is emitted for every kWh of electricity produced within the Danish energy system.

A 35 kW Stirling plant would be able to reduce the CO₂ emission by 149 tonnes per year. If we set the value of one tonne of CO₂ at DKK 150, we arrive at yearly savings of DKK 22,350 or DKK 335,000 during the expected plant service life of 15 years.

By establishing 700 such plants throughout Denmark, we would cut CO₂ emissions by 104,000 tonnes per year, which amounts to 8% of the CO₂ cut that our current government wants to obtain by means of measures other than the quota restrictions already in place for certain companies.

Problems

Currently, six 35 kW Stirling plants are operating in Denmark, Austria and Japan, and two new commercial plants are under construction.

The main obstacle when it comes to penetrating the market is the lack of an attractive home market. There are plenty of interested clients but because green electricity is not very highly valued in Denmark, it is difficult to make ends meet.

To date, around ten engines have been constructed in small series of 1-2 units. Our analysis shows that engine production prices can be cut by 30-50% when producing 25 units or more at a time. Such a cut of expenses would make our technology much more competitive within a long range of markets, even without financial support. It would be a self-reinforcing process; lower prices lead to larger sales and larger production volumes, which in turn would cut production costs and thereby reduce prices further.

It is of utmost importance for Stirling Denmark that we penetrate the market quickly within the next few years by establishing a range of demonstration plants. These plants will demonstrate the flexibility of our technology and increase the demand for new plants, whereby we will be able to reduce production costs.

We expect to deliver engines with a total volume of 100 cylinders within the next two years. Half of these engines are expected to be sold to the German market, where the guaranteed price of green electricity is almost three times as much as in Denmark.

Lars Jagd is managing director at Stirling Denmark, lj@stirling.dk. ■

Algae - a great success

According to American experiments, algae are able to produce 37 times as much biomass as corn and 140 times as much as soya beans.

The American companies Arizona Public Service Company and Green-Fuel Technologies have successfully been able to multiply algae production by adding CO₂ stemming from a CHP plant based on natural gas. Algae – used in bio fuel production, amongst other things – have proven to be clearly superior to traditional agricultural crops when it comes to producing the largest amounts of biomasses within a given area. In this way, these American companies have demonstrated that algae produce 37 times as much biomass as corn and 140 times as much as soya beans, given that large amounts of CO₂ are added.

The two companies are now embarking on new experiments that will involve using CO₂ from a CHP plant based on natural gas instead of CO₂ from a coal-based plant. *TS*

Source: www.greenfuelonline.com



photo: torben skøtt/biopress

Weiss puts DTU research to use

One of the most well-known producers of equipment for the district heating sector in Denmark, Weiss A/S in Hadsund, wants to become one of the leading producers of biomass gasification plants. Before the end of the year, the company will inaugurate the first plant, established within their factory in Hadsund, and the long-term aim is to make this new technology a worthy replacement of the numerous natural gas CHP plants in Denmark.

By Torben Skøtt

It has taken a long time - too long, some might say - but now the goal is within reach. The technology for biomass gasification developed with great success at the Danish University of Technology throughout the 1990s is slowly but surely making its way to the industrial market. Recently, the company TK Energi delivered a gasification plant to the village Gjøøl in the north of Jutland; in the north of Zealand, BioSynergi Proces is finishing the development of facilities at the local CHP plant in

Græsted, and recently, Weiss A/S in Hadsund inaugurated a new plant that has been paid a lot of attention, particularly by foreign investors.

What these three plans have in common is that they are all capable of converting biomasses to a gas that is clean enough to be used directly in an engine connected to an electrical generator. Given the right framework, it will thus be possible to make ends meet even with small CHP plants, giving the tech-



photo: torben skøtt/biopress

Project manager Bjarne Skyum next to the coke reactor. The long container in the top left corner contains the pyrolysis unit.

nology the possibility of becoming a worthy replacement of the numerous natural gas CHP plants across the country.

Tar-free gasification is a Danish speciality developed by a group of researchers from the Danish University of Technology headed by associate professor Ulrik Henriksen. Amongst other things, he developed the so-called wiking-gasifier, which has already been running for 2,000 hours and has the world record in electrical efficiency levels within the category of small biomass CHP plants.

The new Weiss plant is a further development of the wiking-gasifier but it is about ten times the size and constructed in a way that makes it relatively easy to up-scale it to an even larger plant.

The plant in Hadsund will be started up at the beginning of December 2007. This start-up will be followed by a long test period and if everything goes according to plan, the plant will then be moved to the facilities of one of the potential clients.

Who gets there first?

– We are receiving a lot of enquiries from abroad; these enquiries are mainly from Germany but also Eastern coun-

tries are showing a great interest in the concept because it would provide them with a way to ensure a stable electricity supply based on local resources, says Bjarne Skyum of Weiss A/S. He is annoyed that there is no national market for this type of plants; however, he hopes that the Danish government will soon create the financial framework needed to establish such plants in Denmark.

– Selling a couple of plants in Denmark before going international would be a huge advantage. On the other hand, we cannot wait forever. At the moment, companies are fighting intensely to become the first to deliver turnkey plants, a similar development to that of the windmill industry in the 1980s, explains Bjarne Skyum.

In March 2008, the plant will be presented to the public at an international conference on new biomass technologies, and it will be exciting to find out how Weiss is doing compared to foreign producers. The conference will be attended by Weiss employees as well as representatives from the engineering company COWI and the Danish University of Technology, who both took part in the development of the new gasification plant.

Leading technology

The two-step-gasifier was initially designed to use straw as raw material but in the mid-1990s, development efforts started to concentrate on wood chip gasification instead. In the following years, a long range of experiments were carried out at the Institute for Mechanics, Energy and Construction within the Danish University of Technology. The main highlight was the development of the wiking-gasifier, which has proven to be a reliable plant featuring a very high electrical efficiency level.

Nowadays, the idea of dividing the gasifier into several steps is recognised as one of the leading gasification principles world-wide and at one point, the Energy Research Centre of the Netherlands (ECN) actually elected the two-step gasifier as the best technology in terms of environmental issues and electrical efficiency levels.

Within the wiking-gasifier, the process was divided into two steps for pyrolysis and coke gasification respec-



photo: torben skjøtt/blopress

Technicians installing the remaining coke reactor parts. The red container at the back contains the bag filter, and on the left is the screw conveyor that takes wood chips to the desiccation unit.

In step two, more air is added and the temperature increases to around 1,000° C. Now, the hot gas passes through a so-called coke bed, where the coke particles are transformed. The result is a tar-free gas that can be used as fuel in a gas engine following a cool-down period and a simple cleaning procedure in a bag filter.

tively. The first step heats the biomass to around 500° C, whereby a number of chemical connections are split and the fuel is converted into coke and tarry gas.

External fuel desiccation

– Basically, the Weiss plant is designed just like the wiking-gasifier but it is, amongst other things, equipped with a separate unit for fuel desiccation, ex-

This is how the two-step gasifier works

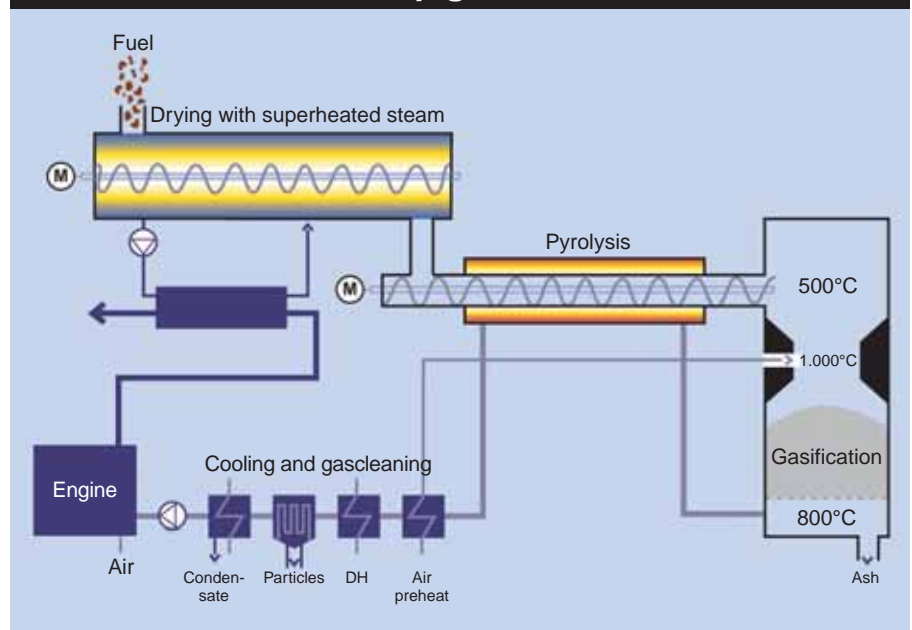

In a two-step gasifier, the process is divided into two parts: pyrolysis and coke gasification. In the first test plants at the Danish University of Technology, fuel desiccation took place within the pyrolysis unit but in the new Weiss plant, the separate desiccation unit makes the process consist of not two, but actually three steps.

Once the fuel has been desiccated by means of overheated steam, the fuel is heated up in the

pyrolysis unit, whereby a coke fraction and a fraction of tarry gas are released. Once air is introduced in-between the two reactors, the tar material is disintegrated. When the products are then led through the coke reactor, the coke is converted into gas. Subsequently, the gas is cooled down by means of a heat exchanger, and the soot particles are collected in a normal bag filter.

The University of Aarhus focuses on bioenergy

The faculty of Agricultural Sciences within the University of Aarhus has chosen to spend a relatively large part of its research resources on bioenergy.

The exact amount to be invested in this field is DKK 6.2 million over the next three years. Recently, the faculty inaugurated the world's largest biogas test plant within the research centre in Foulum, which means that they are well-equipped to carry out research in that particular field.

There is a great need to find out which technologies foster the best environmental value for money when using an increased amount of biomasses. In that connection, the researchers will calculate potential biomass resources and analyse the amount of greenhouse



photo: torben skætt/biopress

The researchers will focus on biogas and energy crops, amongst other areas.

gasses released by the various sources of energy. At the same time, they will look at cultivation aspects of potential sources of bioenergy, as well as the usage of pesticides and loss of nutrients to the environment, and analyse the effect on foodstuff production.

The research resources will not only be spent starting up the new test

plant but also on carrying out a range of specific tasks within the field.

This includes emission measurements; emission of methane and other greenhouse gasses; biogas production based on energy crops; biogas for the transport industry, and sustainable acreage usage focusing on low-lying areas.

TS

► plains engineer Jens Dall Bentzen of COWI A/S. He is one of the leading researchers behind the development of the new plant, along with associate professor Ulrik Henriksen of the Danish University of Technology and project manager Bjarne Skyum from Weiss A/S.

– In the wiking-gasifier, desiccation took place in the pyrolysis reactor itself, but we reckoned that this would turn into a limiting factor in larger plants. Therefore, we chose to use an external desiccation unit that has proven to be a fast and efficient method of wood chip desiccation, says Jens Dall Bentzen.

Two different cultures

Bjarne Skyum is fully aware that the plant construction period was very long, the main reason for this being significant company growth over the past years.

– We have had more than enough to do just dealing with the demand for traditional incinerator plants. Therefore, it has sometimes been difficult to find time for the development efforts needed to bring a new technology to the market, says Bjarne Skyum.

– It has been extremely exciting to work with the researchers despite certain problems arising from two different cultures meeting each other. Whereas the researchers are very creative, con-

stantly coming up with new ideas, we are more concerned with financial aspects and with ensuring that our clients are not faced with any unpleasant surprises, says Bjarne Skyum. All in all, however, he has enjoyed the co-operation and makes no secret of the fact that without researcher support, the project would never have succeeded.

– We are a relatively small company and we would never have been able to carry out a development project of such

a magnitude on our own. Being able to tap the expertise available at the Danish University of Technology, as an example, has definitely been crucial to us, and we will continue to need their support in the years to come in order to make the project succeed, says Bjarne Skyum.

The development of the Weiss gasification plant has been financially supported by the PSO resources administered by Energinet.dk. ■



photo: torben skætt/biopress

The Weiss gasifier is equipped with a separate unit that desiccates the fuel before it is led into the pyrolysis reactor.

From waste water sludge to green oil

Recently, the development company SCF Technologies inaugurated a so-called supercritical plant for conversion of waste water sludge to biooil. The next step will be up-scaling the technology and testing new types of waste and biomasses.

By Torben Skott

On Friday September 28th, the development company SCF Technologies in Herlev presented the first Danish plant for conversion of waste water sludge to biooil. The conversion is based on a so-called supercritical process, which basically imitates those conditions that have created the oil reserves of our earth.

The SCF Technologies plant opens up a whole new world when it comes to creating sustainable biofuel production because it does not use raw materials that, alternatively, could have been used



photo: lars bertelsen/ingeniøren

for food production purposes. Throughout that last six months, the plant in Herlev has been converting waste water sludge to biooil, and SCF Technologies are now getting ready to test new raw materials in the production process, including sugar beet pulps and residual products from bioethanol production.

The SCF Technologies pilot plant that converts waste water sludge to oil, which can be processed into biodiesel. The company is expecting to sign the first licence agreements on the establishment of demonstration plants next year.

– We have obtained good results so far, and the quality of the oil, which we produce, is now at the wanted level, says Karsten Felsvang, managing director at SCF Technologies.

– We use waste water sludge and waste from the foodstuff industry as raw materials, and during the process, we are able to separate out chlorine and sulphur so that the oil, when incinerated, generates less pollution than fossil oil, explains the managing director, who makes no secret of the fact that he considers the technology a bit of a scoop.

Co-operation

SCF Technologies co-operates with the company Grundfos, as well as the universities of Aalborg and Aarhus, in order to finalise the process developments. The most challenging part is making the technology commercially available by proving that it is both widely applicable to many types of organic waste and biomasses, and that the good results from the pilot plant in Herlev can in fact be up-scaled to larger plants. The aim is to develop a plant that can be used by other companies to convert their own organic waste to biooil. SCF Technologies expects the first licence agreements on the establishment of demonstration plants to be signed in 2008.

The plant in Herlev treats 20 kilos of waste water sludge per hour. It typically contains four kilos of dry materials, sufficient to produce two kilos of oil. The oil can then be processed into biodiesel, and before the end of the year, the oil will be tested as fuel for diesel engines.

Last autumn, the Danish National Advanced Technology Foundation allocated almost DKK 10 million to the development of this new technology. More than DKK 6 million were directly paid out to SCF Technologies, whereas the rest was paid out to their co-operation partners. ■

This is how a supercritical process works

A supercritical process utilises the range of chemical reactions that take place within organic material exposed to high pressure and temperatures. This phenomenon is known from everyday life on a smaller scale, e.g. when vegetables turn soft and tender after having been treated in a pressure cooker.

At even higher pressure and temperature levels, the organic material is completely disintegrated into indi-

vidual molecules. They, in turn, react chemically with water, and by using a suitable catalyst, these reactions can be controlled in order to create a specific product. This makes a conversion of liquid organic material into oil possible.

Basically, the supercritical process is able to imitate the conditions, which have created the oil reserves of our earth throughout millions of years, in a few minutes.

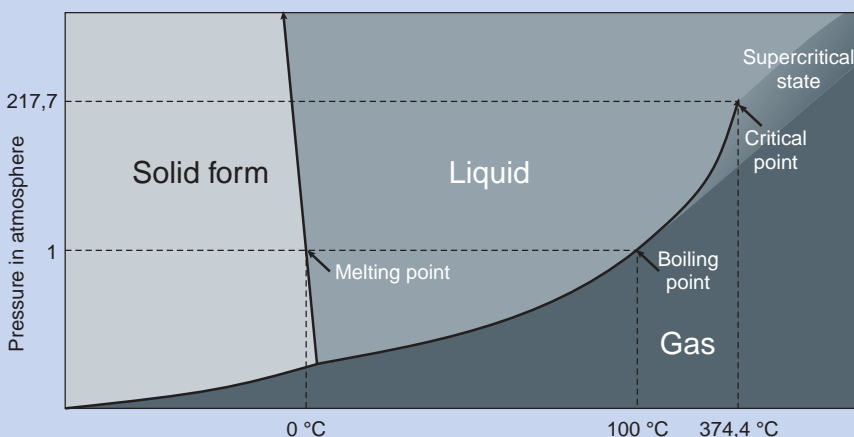

Re-establishing the biogas process

The biogas plants can lead to massive savings if we intervene as soon as the biological process shows signs of an imbalance. Biomass dilution and the addition of fresh or degasified biomasses can provide important tools, but it is difficult to pinpoint the best strategy. This is what a number of experiments, carried out by researchers at the Danish University of Technology, have shown.

By Henrik Bangsø Nielsen
and Rena Angelidaki

Most biogas plants have been subject to interruptions to a smaller or larger extent, and many plants might even have seen the process collapse altogether. Such break-downs can lead to serious financial consequences for the plant, and plant managers are obviously very concerned with this issue.

Interruptions and break-downs are often linked to the type of biomasses used in the plant, and unfortunately it turns out that a combination of manure



photo: torben skott/biopress

Adding fresh biomasses can be an important tool when the biological process shows signs of an imbalance. The picture shows the community plant in Nysted, Lolland.

and organic waste can be a dangerous cocktail. If the mixture contains a lot of proteins and fat, this might lead to high concentrations of ammonium and longchained fatty acids (LCFA), which might inhibit the process.

The best way to avoid such problems is to have a profound knowledge of the type of biomasses used, both in terms of chemical structures and biomass disintegration processes within the plant.

Furthermore, it is important to be able to dose the various types of waste in a precise manner and carry out detailed process surveillance.

Unfortunately, the plants do not always accommodate the fulfilment of these requirements. Precontainers are limited in terms of size and number, often forcing plant managers to mix the waste. Another problem is the variation in waste composition, amount and de-

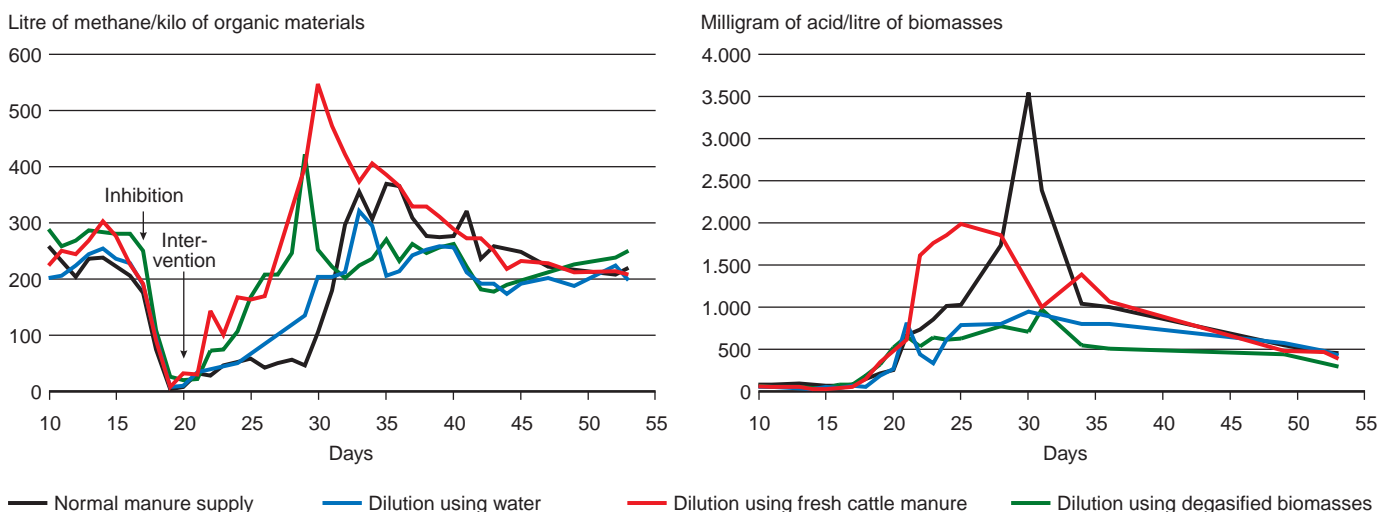

Figure 1: Experiments on re-establishing the biogas process in various reactors in which the ammonium concentration was increased from 1 milligram to 9-11 milligram per litre of biomass in 17 days. No intervention was applied to the first reactor which was simply supplied with the usual amount of manure. In the three other reactors, half of the reactor content was replaced with water, degasified biomasses or fresh manure three days after inhibition. These reactors were also supplied with the same daily amount of manure as before the inhibition set in. The reactor temperature was 52° C throughout the experiments, and the average retention time was 15 days.

livery frequency because it might force the plants to supply the reactors with a certain type of waste at a time when this might cause instability within the biological process. Finally, a complete surveillance system, involving all process parameters, is a time-consuming and expensive solution, which means that surveillance is insufficient at most plants.

As a consequence of these limitations, biogas plants are subject to various types of interruptions at regular intervals. Therefore, the question is: what can plant managers do in order to re-establish the process quickly upon noticing a gas production decrease?

At the institute of Environment and Resources within the Danish University of Technology, we have carried out a range of experiments on re-establishment of biogas processes in laboratory reactors. Supported by the Energy Research Programme, the experiments were primarily based on biomass dilution using water, manure or degasified biomasses. The process was inhibited by adding ammonium or LCFA to four reactors containing cattle manure. Figures 1 and 2 show the results of the various strategies and contain experiment descriptions.



photo: torben skøtt/biopress

The combination of manure and organic waste generates large amounts of gas; however, it can also turn into a dangerous cocktail that, in a worst case scenario, could bring the biological process to a complete stop. This picture shows how catering centre waste is being unloaded at the biogas plant in Hashøj by Slagelse.

Ammonium inhibition

Following ammonium inhibition, it turned out that the most efficient method of re-establishing the process was to replace half of the reactor contents with degasified biomasses or fresh cattle manure (see figure 1). Whereas this strategy caused the gas production to return to its initial level within 6 days, it took 10-11 days to re-establish the process when adding 50% water or when cutting the daily supply of manure in half.

After almost 6 days, a significant gas production increase was noted in the re-

actor that had been provided with 50% fresh cattle manure. During the entire re-establishment process, this reactor produced between 42% and 74% more gas than the other reactors, which is explained by the extra amount of organic material that was added in the form of fresh manure.

One should, however, also note the development in acid levels during the re-establishment process; it shows how stable the process is. It turned out that the acid level increase was somewhat

continued on page 13 ►

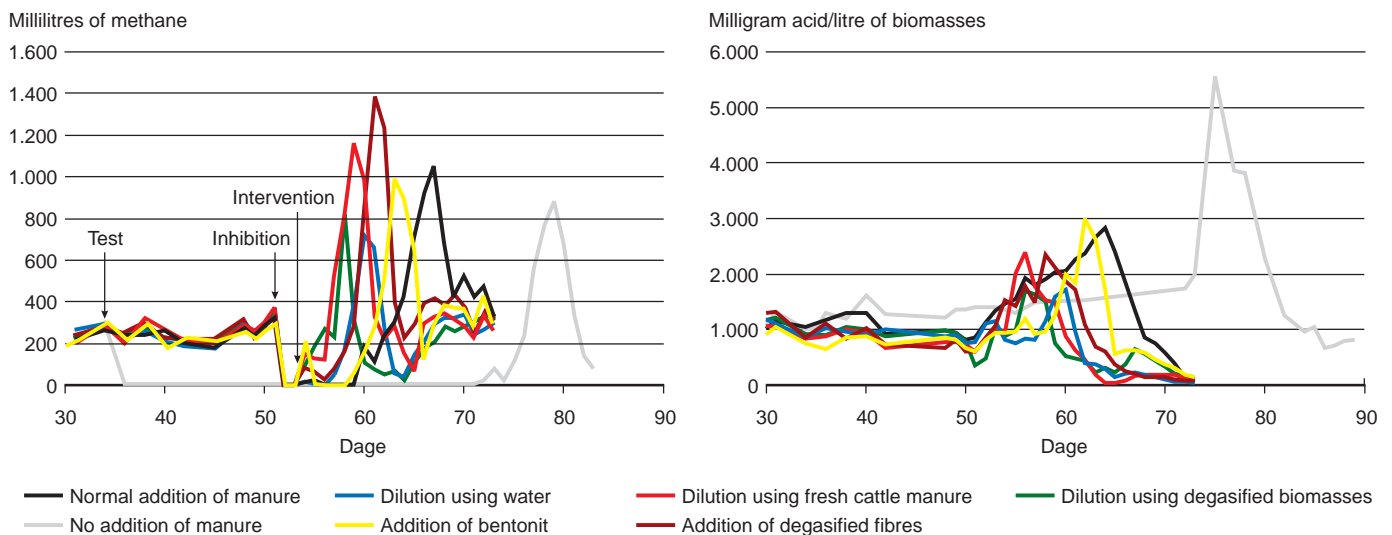

Figure 2. Experiments on re-establishing the biogas process following the addition of 5 grams of oleate (C18-fatty acid) per litre of biomasses. In the first reactor, oleate was added after 34 days in order to ensure that a significant inhibition would occur (inhibition test). Afterwards, no further interventions, and no addition of biomasses, were carried out on that reactor. The other six reactors (test reactors) were inhibited after 50 days. In one of these reactors, only the normal amount of manure was added. In three other reactors, half of the reactor content was replaced by water, degasified biomasses and manure, respectively, three days after inhibition. In the two remaining reactors, 8.7 grams of degasified manure fibres per litre of biomasses or 5.0 grams of bentonit per litre of biomasses, respectively, were added. After 63 days, the normal amount of manure was added to the six test reactors. The reactor temperature was 52° C throughout the experiments, and the average retention time was 15 days.



photo: torben skøtt/biopress

Biogas experiments on a large scale

– *Research Centre Foulum inaugurates the largest test plant in the world*

A new test plant within Research Centre Foulum is expected to make it easier for researchers to optimise gas outputs of livestock manure and energy crops, amongst others. Currently, we are only utilising around half of the gas potential contained in biomasses, which means that there are great perspectives for improvement of new and existing biogas plants.

By Torben Skøtt

On Tuesday October 30th 2007, the World's largest biogas test plant was inaugurated at Research Centre Foulum, now part of the Faculty of Agricultural Science at the University of Aarhus. The inauguration saw a lot of positive feedback about the plant, but also a certain level of frustration with the fact that it has taken almost ten years to finish the project.

– We want the new biogas plant to contribute to the process of placing Denmark at the global forefront within the field of utilising energy and nutrients from livestock manure and other types of biomasses, the Minister of

Food, Agriculture and Fisheries Eva Kjer Hansen expressed through a press statement that was released at the time of the inauguration. The minister did not take part in the event at the research centre because she had chosen to dedicate her time to the election campaign going on at the time. Bent Hansen, chairman of the region of Mid-Jutland, and Martin Merrild, who is the mayor of Struer and has a number of positions of trust within the agricultural industry, did participate in the event. They opened the gas tap together, marking

the inauguration of the plant worth DKK 25 million.

Two plants

In fact, Foulum features two, not just one plant: a test plant and a production plant. The latter will be handling around 29,000 tonnes of manure and around 2,000 tonnes of biomasses stemming from stables and fields belonging to Research Centre Foulum. This will generate around 850,000 cubic metres of methane gas, which will be converted into heating and electricity within the local CHP plant.

The test plant itself contains four reactors with appurtenant precontainers, as well as the dosing system for feed-in of solid products such as forage remains, floor bedding, energy crops etc. This makes the plant one of the most advanced and flexible test plants in the world.

– We expect the various technological measurements, which will be tested within the new plant, to make biogas plants of the future more effective and stable in operational terms, and to obtain a larger total environmental win than what has been generated so far in the first plants, said Gunnar Hald Mikkelsen, operations manager at the new plant.



photo: torben skøtt/biopress

Together, Bent Hansen (left) and Martin Merrild opened the gas tap, marking the plant inauguration.

Apart from carrying out research with a view to optimise processes within the biogas reactors themselves, it will also be possible to carry out experiments on various types of biomasses. By being located within Research Centre Foulum, an extensive base of raw materials from the centre's production livestock, including dairy cattle, pigs, poultry and minks, will be readily available for utilisation within the plant. Furthermore, the centre is able to supply energy crops, straw and other types of biomasses.

There is still plenty of work to do before the entire biogas potential can be fully exploited. In existing plants, the conversion of organic material from livestock manure and straw, as an example, is only 50-60% of what is actually possible in theoretical terms.

Many ideas have been drawn up on how to improve biogas production methods, but very often, scientific proof



photo: torben skøtt/biopress

Managing director at Xergi, Frank Rosager (at the rostrum) passes on the "starter switch" to Martin Merrill and Bent Hansen (left).

and practical method tests are lacking. One of the tasks of the new plant is to deal with this shortcoming. The plant, financed by the Ministry of Food, Agriculture and Fisheries, will provide researchers, students and biogas producers alike with completely new possibilities of developing technologies on a large scale.

The company Xergi is one of the producers, who is definitely going to use the new plant. Xergi has been in charge of delivering the plant, and they have placed their development department at the Centre for Bioenergy and Environmental Technology Invention, one of Research Centre Foulum's neighbours. ■

► *continued on page 11*

higher when adding fresh manure than when adding degasified biomasses. It definitely seems that the most efficient and safest method of ammonium inhibition is a combined addition of manure and degasified biomasses.

The worst thing to do is to continue adding the daily amount of manure, or to dilute the biomass using water. Adding water leads to a faster process re-establishment than if nothing had been done, however, this strategy leads to a relatively low gas production level. The reactor, which saw no intervention efforts at all, also saw the most significant acid level increase, indicating that the process in this particular reactor was influenced more than in any other one.

LCFA inhibition

Biogas process inhibition by means of adding LCFA showed more or less the same results as the ammonium inhibition experiments (see figure 2). When the biomasses were diluted with degasified biomasses and manure respectively, the biogas production was re-established within 3-4 days. When adding water, it took 5-6 days, and when not intervening at all, the biogas production was re-established after 10 days.

This line of experiments also tested the extent to which an addition of rotten fibres and bentonit would influence the process. Whereas the fibres worked fast (6 days), bentonit worked a little slower (8 days). Nevertheless, the latter was more effective than when just adding the daily amount of manure. Cutting off manure supplies altogether lead to a very inefficient re-establishment process that lasted 42 days.

Once the process had been re-established in all reactors, the experiments were repeated (not shown). When replacing half of the biomasses with fresh manure or degasified biomasses, the response time was the same as in the initial experiments, but when simply adding the daily amount of manure, the process happened a little bit faster (9 days). This shows that the process is capable of adjusting to a higher LCFA concentration level. Adding fibres made the process work a little bit slower than in the initial experiment (8 days), but adding bentonit (18 days) and water (21 days) made the process work markedly slower this time around.

Conclusion

The experiments led to the overall conclusion that following a process interruption caused by ammonium or fat, it

is important to dilute the biomasses as this leads to a reduced concentration of inhibiting materials. However, dilution is not the only important factor; adding a substrate in the form of fresh or degasified biomasses is also needed in order to obtain a satisfactory re-establishment of the process.

As the process inhibitions might vary from one interruption to the next, it is difficult to pinpoint the best strategy. The results might serve as a source of inspiration and reference when a plant manager wants to select a strategy for dealing with an imbalanced process. Before selecting a particular strategy, conditions such as temperature levels, organic load, waste composition and the reason for the imbalance must also be taken into consideration.

Henrik Bangsø Nielsen has a PhD. and is Post Doc at Risø, Danish University of Technology.

Rena Angelidaki has a PhD. and is a professor at the Institute of Environment and Resources, Danish University of Technology.

1. See also the article "Optimisation of the biogas process" in Bioenergy Research no. 13-2006, pages 1 - 4. ■

New seminar: business plans for project applicants

The project market is currently growing at an explosive rate and at the same time, project providers want to be sure that the chosen projects can in fact be turned into business. Project applicants are thus required to possess a new set of competences in order to be able to draw up business plans and make render that the project will generate a commercial output in the long term.

1st Mile, specialising in converting projects into business, now offers a seminar on business plan preparation. The seminar lasts 1-2 days and provides the participants with the ability to:

- understand the difference between project subsidies and capital investments from investors;

- understand how investors think and prioritise;
- understand the elements of a business plan;
- draw up a business plan for a concrete project, written for a private investor;
- write a business plan that meets the requirements entailed in publicly financed research programmes.

Seminar prices depend on the number of participants as well as accommodation and catering requirements. For further information, contact:

Søren Houmøller

☎ 0045 4044 6714 • www.1stmile.dk

We have: DKK 31 billion

We want: world-class environmental and energy research

The Danish Agency for Science, Technology and Innovation is looking to explore current possibilities of applying for EU subsidies for environmental and energy-related projects. This process will take place within two theme meetings on December 10th and 13th in Copenhagen and Aarhus, respectively.

By Nina Espegård Hassel

The debate on climate changes is becoming more and more intense. This is one of the largest environmental challenges that we have ever faced, and the EU is providing large-scale subsidies to research and development efforts dealing with this challenge.

Amongst other things, the EU Seventh Framework Programme for research and technological developments, available until 2013, focuses on research and development within the fields of environment and energy in order to handle the challenges caused by climate changes.

More information on these possibilities

The Danish Agency for Science, Technology and Innovation is looking to explore current possibilities of applying for EU

subsidies for environmental and energy-related projects. This process will take place within two theme meetings on December 10th at the Danish Meteorological Institute in Copenhagen and on December 13th at the city hall of Aarhus.

These meetings will focus on new subject areas, from within which business people and researchers alike may apply for EU subsidies, as well as EU requirements. Furthermore, Danish perspectives in the fields of environment and energy will be outlined and good advice on applying for and carrying out EU projects will be offered.

Registration

You can register with Helen Thorboe, email hbt@fi.dk. Take a look at the agendas for the meetings at www.rammeprogram.dk – click on “Arrangementer og kurser”.

Nina Espegård Hassel is chief clerk at EuroCenter, an organisation offering information and advice on EU research programmes; assistance to foreign researchers working in Denmark; and assistance in technology transfer processes. Eurocenter is part of the Danish Agency for Science, Technology and Innovation.

EU subsidies for energy projects

The energy section within the EU 7. Framework Programme is giving pride of place to research that will improve and contribute to the restructuring process of the current energy system. This includes anything from biomass research and wave energy to knowledge as the base of energy-political decision-making. For the years 2007-2013, around DKK 17 billion have been earmarked for:

- developing a sustainable energy system;
- increasing energy efficiency levels;
- improving energy security and reducing climate changes;
- improving the competitive performance of the energy sector.

Further information: Nina Espegård Hassel, telephone number 0045 3544 6293, or visit www.rammeprogram.dk.

EU subsidies for environmental projects

The environment programme will assist in creating a sustainable administration of the environment and its resources. This is going to happen by increasing our knowledge on the interaction between climate, biosphere, ecosystems and human actions. For the years 2007-2013, around DKK 14 billion have been earmarked for the following focus areas:

- climate changes, pollution and risks;
- environmental technology;
- earth observation and evaluation tools;
- sustainable resource administration.

Further information: Hans Henrik Lomholt, telephone number 0045 3395 5255, or visit www.rammeprogram.dk.

Grate incineration of biomasses

Titel: 4730 - Joint biomass project: Development of a general model for grate incineration of biomasses.

Project manager: University of Aalborg, Institute of Energy Technology, Lasse Rosendahl - Tel.no. 0045 9635 9240

Grant: PSO - DKK 3,812,000

The project consisted of two parts: establishing test facilities and creating a module describing the process of biomass incineration in grate-fired CHP plant boilers. Establishing the test plant was a success, and it is continuously used by researchers and students, who want to do their final projects on biomass incineration. Creating the module, however, turned out to be much more complicated than expected and so far, the researchers have given up on using that part of the project.

Gasification plant in Græsted

Titel: 5288 - Modelling, verification and long-term testing of a stepped gasification plant's operational characteristics with regards to varying electricity and heating outputs.

Project manager: BioSynergi Proces ApS, Henrik Houmann Jakobsen Tel.no. 0045 4586 1430

Grant: PSO - DKK 1,642,000

This project provided a wider insight into gasification plants based on the so-called Open Core principle. The experiments were carried out at the Castor plant within the CHP plant Græsted Fjernvarme in the north of Zealand, headed by Henrik Houmann Jakobsen from BioSynenergi ApS. The main project activities were reconstructing and testing the plant for operation during part-load experiments; developing start/stop procedures; operational measurements within the reconstructed CHP plant; and developing a static computer model. Back then, when the Castor plant was established based on subsidies from the Danish Energy Agency, it was only designed for full output operation. Upon completing this present project, the load can be reduced to around 40% of the maximum output of 425 kW. The measurement programme showed, amongst other things, that the gasifier produces a fine gas featuring a relatively stable composition.

Gasification plant in Gjøel

Titel: ENS-1373/03-0004 - LIFTOFF gasification plant in Gjøel

Project manager: FORCE Technology, Aage Damsgaard - Tel.no. 0045 7215 7700

Grant: EFP - DKK 2178,000

Originally, the goal of this project was to carry out a measuring programme and finish the development of the gasification plant in Gjøel in the north of Jutland. The plant construction process saw some serious delays, however, which meant that the gasifier was not run in until very recently. Therefore, it has not been possible to carry out a measuring programme, and the resources from this project have been spend on dimensioning and finishing the plant instead.

Alternative additives

Titel: 6532 - Alternative additives

Project manager: Dong Energy A/S, Lasse Tobiasen, Tel.no. 0045 9955 1111

Grant: PSO - DKK 2,600,000

Previous theoretical studies involving various types of additives have generated positive results. Many of these additives, however, are too expensive to be put to practical use in full-scale plants, and the aim of this project was to analyse the possibilities of utilising a number of cheaper alternatives. These were:

- dry matter fractions from degasified manure
- paper sludge
- foundry sand
- used bleaching clay
- anorthosit
- sand
- clay remains

Most of these alternative additives turned out to be unsuitable; either based on the lack of a chemical effect or because of excessive pre-treatment requirements, especially desiccation. Bleaching clay and clay remains were the only additives that were capable of reducing fur, however, clay remains is a very wet clay fraction, and desiccation would make up a significant barrier to utilisation. On the contrary, used bleaching clay requires very little in terms of pre-treatment, making this the most promising suggestion for an alternative additive. Because of its oil content, however, in legal terms, this product is considered a waste product that, amongst other things, carries a fee of DKK 330/tonne. When using additives, larger amounts of ashes must be disposed of. All in all, this might lead to a significant additional expenditure, particularly with regards to fuels with high ash contents such as straw, because additive addition is proportional with the ash content of the fuel. Overall, using alternative additives is not financially attractive because it will lead to a fuel price increase of at least 3%, when using wood as fuel, and 8% when using straw. These expenditures would only outweigh the potential savings on operational and maintenance costs in special circumstances.



photo: torben skjøtt/biopress

Alternative additives have been tested at Køge CHP plant, amongst other places.

FiB – Bioenergy Research is published with support from Denmark's Energy Research Programme. The newsletter, which is free of charge, is published six times a year both in a Danish and an English version. Both versions can be downloaded from the Internet at the following homepage: www.biopress.dk

The Danish version of the newsletter is also available in a printed version. Further copies of the Danish version can be ordered from BioPress, via the following e-mail address: biopress@biopress.dk, or telephone nr +45 8617 8507.

Editor responsible:
Torben Skøtt

ISSN: 1604-6358

Production:
BioPress
Vestre Skovvej 8
DK-8240 Risskov
Denmark
Telephone +45 8617 8507
E-mail: biopress@biopress.dk
Homepage: www.biopress.dk

Photo on the front page:
Torben Skøtt/BioPress

Reproduction of articles or illustrations has to be accepted by BioPress. It is allowed to quote articles if the source is clearly indicated.

Next issue:

– to be published in the middle of December 2007. The deadline for articles is 15 February 2008.

Biodiesel protects our health – but strains the environment



Australian researchers make it clear that car exhaust gasses from a car running on biodiesel contain far less harmful components than those from a car using normal diesel. On the contrary, biodiesel carries just a few, if any, environmental advantages; German researchers are now pointing out that very often, biodiesel emits more greenhouse gasses than traditional diesel.

By Torben Skøtt

It is well-known that exhaust gasses cause serious health problems such as heart diseases, bronchitis and asthma, but it was only recently that researchers found out that biodiesel is much less harmful than traditional diesel.

The results originate from experiments carried out by a group of researchers at Deakin University in Australia, headed by Professor Leigh Ackland. In a laboratory, experiments were carried out in order to find out how cells from human respiratory passages react when being exposed to various types of exhaust gasses.

The results were very clear; in the experiments involving traditional diesel, the researchers established that a large amount of cells would join each other and die, whereas hardly any dead cells were found in the experiments involving biodiesel.

– Exhaust gasses from diesel are clearly much more harmful than those stemming from biodiesel, says Professor Leigh Ackland in a press release from Deakin University. He highlights the risk of various respiratory passage conditions, such as asthma, as well as the increased risk of developing lung cancer.

Biodiesel is good for our health but on the contrary, several research efforts point out that the environmental advantages are very limited and that, in certain cases, it might in fact be harmful to the climate to replace traditional diesel with green diesel. On October 30th 2007, at a conference in “Industriens Hus”, the Institute for Energy and Environmental Research in Germany presented a lifecycle analysis showing that biodiesel produced on the basis of soya beans and palm oil, amongst other things, might lead to a more extensive CO₂ emission than traditional diesel. When the raw material is rape oil, a yearly CO₂ displacement per hectare of around three tonnes can be expected, and this result is similar to that of ethanol based on corn. Bioethanol, produced on the basis of sugar cane, offers the best environmental score with a CO₂ displacement of 10-15 tonnes per hectare, and this is in fact a great deal better than that of second-generation bioethanol, which only displaces around five tonnes CO₂ per hectare.